

# SOUS VIDE KITCHEN

# 8 UNITS OF INDUCTION COOKER - 2 HOBS EACH

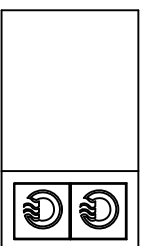

0	REV	DATE	NAME	DESCRIPTION	
THESE DRAWINGS AND SPECIFICATIONS ARE THE PROPERTY OF MIDDEBY PHIL'S CORPORATION AND SHALL NOT BE COPIED OR REPRODUCED WITHOUT THEIR WRITTEN PERMISSION.					
<b>WOFEX 2014</b> SMEX, PASAY CITY					
 A Middleby Company 19 TECHNOLOGY AVENUE LAGUNA TECHNO PARK BNAW, LAGUNA					
<b>LIVE COMPETITION B</b>					
DRAWING TITLE:					
DRAWING NUMBER:					
PROJECT NO.:					
DATE: 6/17/2014					
REVISION:					
CAAD FILE:					
SCALE: N T S					
DRAWN BY: JP					
CHECKED BY:					
SHEET NO. 1 OF 1					
APPROVED BY:					

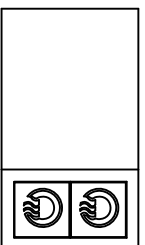
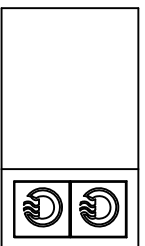
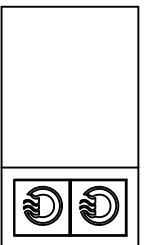
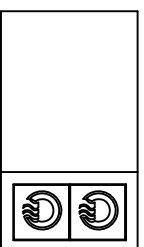
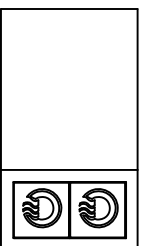
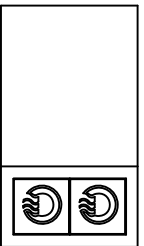
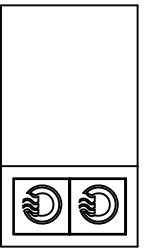

**UNI-FAB METAL INDUSTRIES**

Cavite Office:  
 29 South Coast Industrial Estate BanCAL, Carmona Cavite  
 Tel. No.: 584-4820 to 21, 584-4884 ; (046) 413-0759  
 Manila Office:  
 950-956 Espeleta Street, Santa Cruz, Manila  
 Tel. No.: 733-8241 to 52 Fax No.: 734-7216



Company: \_\_\_\_\_

Project Name: **SOUS-VIDE WOFEX 2014**

Item/Equipment Name: **2-DOOR FREEZER**

Item No./Model No.: **11** Qty.: **2 UNITS**

Dimensions: (Millimeter)

Length	Width	Height	B.S. / O.S.
680	760	1950	_____

**Specifications:**

- » HIGH PERFORMANCE COOLING SYSTEM  
SPECIALY DESIGNED FOR HIGH AMBIENT TEMPERATURE
- » PRECISE TEMPERATURE CONTROL  
ADJUSTABLE BY MICROCOMPUTER AND DIGITAL DISPLAY
- » APPLIED SEAMLESS WELDING TECHNOLOGY

Stanley	CA-680L2
<b>Temp. Range</b>	0°C ~ +12°C
<b>Power Supply</b>	220V/50~60Hz
<b>Capacity</b>	550L
<b>Dimensions</b>	680 x 760 x 1950
<b>Compressor</b>	1/4 Hp
<b>Refrigerant</b>	R134a
<b>Shelf</b>	4 Sets
<b>Illumination</b>	0
<b>40ft Container</b>	51 Sets

DUE TO CONTINUOUS PRODUCT IMPROVEMENT, SPECIFICATIONS AND FEATURES CAN CHANGE WITHOUT PRIOR NOTICE:

**EQUIPMENT PERSPECTIVE**

Sheet Contents:	Revision #	Description of Change	Originator	Revision Date:
<input checked="" type="checkbox"/> Perspective	00	INITIAL RELEASE	DON	
<input type="checkbox"/> Specifications	01			
<input type="checkbox"/> Section Details	02			
<input type="checkbox"/> Elevation	03			
<input type="checkbox"/> Pages: /_	04			

Prepared & Checked By: \_\_\_\_\_  
 Date: \_\_\_\_\_  
 Customer's Approval: \_\_\_\_\_  
 Date: \_\_\_\_\_



**UNI-FAB METAL INDUSTRIES**

Cavite Office:  
29 South Coast Industrial Estate Bancal, Carmona Cavite  
Tel. No.: 584-4820 to 21, 584-4884 ; (046) 413-0759  
Manila Office:  
950-956 Espeleta Street, Santa Cruz, Manila  
Tel. No.: 733-8241 to 52 Fax No.: 734-7216



Company: \_\_\_\_\_

Project Name: **SOUS-VIDE KITCHEN**

Item/Equipment Name: **COOLING RACK, 5-LAYER**

Item No./Model No.: **10** Qty.: **8 UNITS**

Dimensions: (Millimeter)			
Length	Width	Height	B.S. / O.S.
516	700	1500	—

**Specifications:**

**MATERIALS:**

- » 14ga ss#4: angular slide
- » 20ga ss#4: bottom shelf
- » 25square tube: bracing, upright
- » 76Ø PU wheel: all swivel, 2 w/ brakes

**ACCESSORIES:**

- » 2pcs sheet pan tray per layer

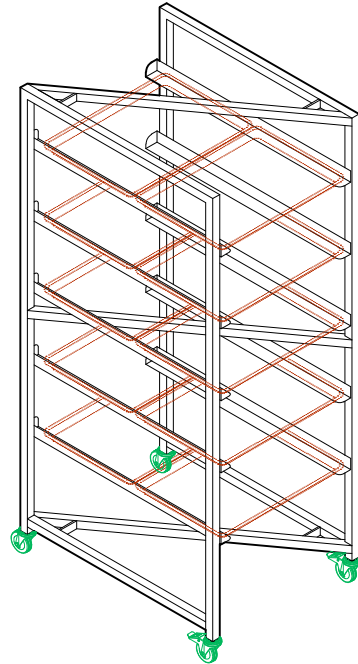

DUE TO CONTINUOUS PRODUCT IMPROVEMENT, SPECIFICATIONS AND FEATURES ARE CHANGED WITHOUT PRIOR NOTICE.

**EQUIPMENT PERSPECTIVE**

Sheet Contents:	Revision #	Description of Change	Originator	Revision Date:
<input checked="" type="checkbox"/> Perspective	00	INITIAL RELEASE	DON	
<input type="checkbox"/> Specifications	01			
<input type="checkbox"/> Section Details	02			
<input type="checkbox"/> Elevation	03			
Pages: ___ OF ___	04			

Prepared & Checked By:   
Date: 03JUL13  
Customer's Approval: \_\_\_\_\_  
Date: \_\_\_\_\_

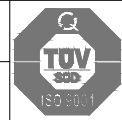

**UNI-FAB METAL INDUSTRIES**

Cavite Office:  
 29 South Coast Industrial Estate Bancal, Carmona Cavite  
 Tel. No.: 584-4820 to 21, 584-4884 ; (046) 413-0759  
 Manila Office:  
 950-956 Espeleta Street, Santa Cruz, Manila  
 Tel. No.: 733-8241 to 52 Fax No.: 734-7216



Company: \_\_\_\_\_

Project Name: **SOUS-VIDE KITCHEN**

Item/Equipment Name: **PREPARATION SINK TABLE**

Item No./Model No.: **9** Qty.: **8 UNITS**

Dimensions: (Millimeter)			
Length	Width	Height	B.S. / O.S.
700	700	865	—

**Specifications:**

**MATERIALS:**

- » 16ga ss#4: top plate, sink bowl, back splash
- » 18ga ss: post frame
- » 25square tube: bracing
- » 38square tube: upright
- » adjustable bullet type footing

**ACCESSORIES:**

- » deck type faucet
- » basket strainer

**SINK SIZE:**

- » 400x400x305D

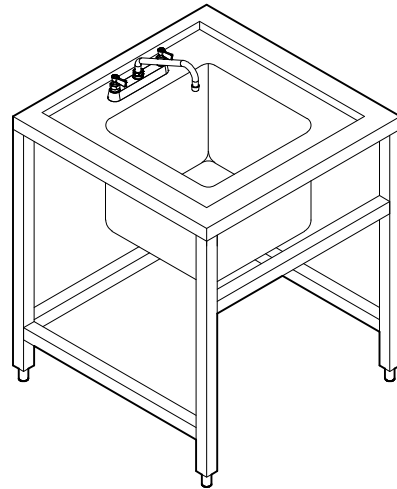

DUE TO CONTINUOUS PRODUCT IMPROVEMENT, SPECIFICATIONS AND FEATURES ARE CHANGED WITHOUT PRIOR NOTICE.

**EQUIPMENT PERSPECTIVE**

Sheet Contents:	Revision #	Description of Change	Originator	Revision Date:
<input checked="" type="checkbox"/> Perspective	00	INITIAL RELEASE	DON	
<input type="checkbox"/> Specifications	01			
<input type="checkbox"/> Section Details	02			
<input type="checkbox"/> Elevation	03			
Pages: ___ OF ___	04			

Prepared & Checked By:   
 Date: 03MAR14  
 Customer's Approval: \_\_\_\_\_  
 Date: \_\_\_\_\_

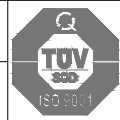

**UNI-FAB METAL INDUSTRIES**

Cavite Office:  
29 South Coast Industrial Estate Bancal, Carmona Cavite  
Tel. No.: 584-4820 to 21, 584-4884 ; (046) 413-0759  
Manila Office:  
950-956 Espeleta Street, Santa Cruz, Manila  
Tel. No.: 733-8241 to 52 Fax No.: 734-7216



Company: \_\_\_\_\_

Project Name: **SOUS-VIDE KITCHEN**

Item/Equipment Name: **UNDER COUNTER REFRIGERATOR**

Item No./Model No.: **8** Qty.: **8 UNITS**

Dimensions: (Millimeter)

Length	Width	Height	B.S. / O.S.
900	700	865	—

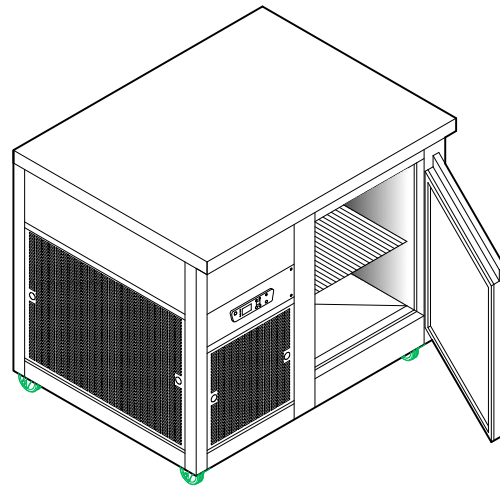

**Specifications:**

**MATERIALS:**

- » 16ga ss#4: top plate, back splash, base frame channeled upright
- » 20ga ss#4: outer body, motor compartment cover louver type, control panel, door panel
- » 22ga ss#4: inner body
- » polyurethane foam in-place insulation
- » 1/2 Hp sealed type condensing unit (OR EQUAL) to fit 400mm wide left space 220V/60Hz/1Ph (Tecumseh 134a)
- » evaporator - blower type cooling system

**ACCESSORIES:**

- » 1pc digital thermostat control (DEI)
- » 1pc magnetic door gasket
- » 1pc filter drier
- » 1pc expansion valve
- » 4pcs 76Ø PU wheel: all swivel, 2 w/ brakes
- » 1set edge mount hinge
- » 1pc wire shelf

DUE TO CONTINUOUS PRODUCT IMPROVEMENT, SPECIFICATIONS AND FEATURES ARE CHANGED WITHOUT PRIOR NOTICE.

**EQUIPMENT PERSPECTIVE**

Sheet Contents:	Revision #	Description of Change	Originator	Revision Date:
■ Perspective	00	INITIAL RELEASE	DON	
■ Specifications	01			
■ Section Details	02			
■ Elevation	03			
Pages: ___ OF ___	04			

Prepared & Checked By:   
Date: 03MAR14

Customer's Approval: \_\_\_\_\_  
Date: \_\_\_\_\_

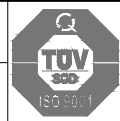

**UNI-FAB METAL INDUSTRIES**

Cavite Office:  
29 South Coast Industrial Estate Bancal, Carmona Cavite  
Tel. No.: 584-4820 to 21, 584-4884 ; (046) 413-0759  
Manila Office:  
950-956 Espeleta Street, Santa Cruz, Manila  
Tel. No.: 733-8241 to 52 Fax No.: 734-7216



Company: \_\_\_\_\_

Project Name: **SOUS-VIDE KITCHEN**

Item/Equipment Name: **PREPARATION TABLE**

Item No./Model No.: **6** Qty.: **8 UNITS**

Dimensions: (Millimeter)			
Length	Width	Height	B.S. / O.S.
1000	700	865	—

- Specifications:**  
**MATERIALS:**
- » 16ga ss#4: top plate
  - » 18ga ss: post frame, stiffener
  - » 20ga ss#4: under shelf
  - » 38square tube: upright
  - » adjustable bullet type footing

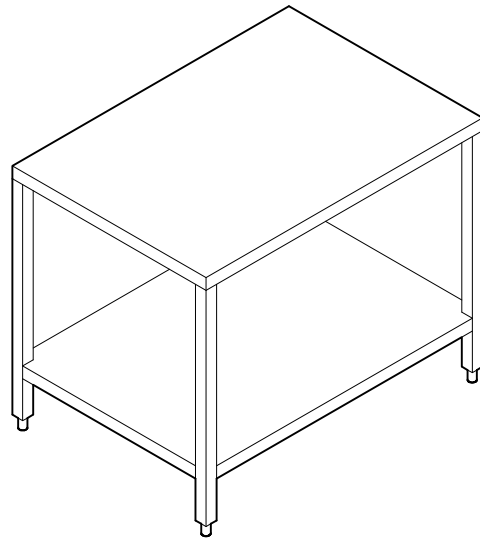

DUE TO CONTINUOUS PRODUCT IMPROVEMENT, SPECIFICATIONS AND FEATURES ARE CHANGED WITHOUT PRIOR NOTICE.

**EQUIPMENT PERSPECTIVE**

Sheet Contents:	Revision #	Description of Change	Originator	Revision Date:
<input checked="" type="checkbox"/> Perspective	00	INITIAL RELEASE	DON	
<input type="checkbox"/> Specifications	01			
<input type="checkbox"/> Section Details	02			
<input type="checkbox"/> Elevation	03			
Pages: ___ OF ___	04			

Prepared & Checked By:   
Date: 03MAR14  
Customer's Approval: \_\_\_\_\_  
Date: \_\_\_\_\_

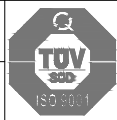

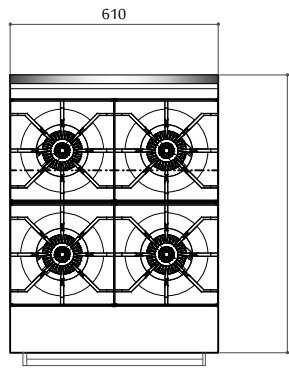

TOP VIEW

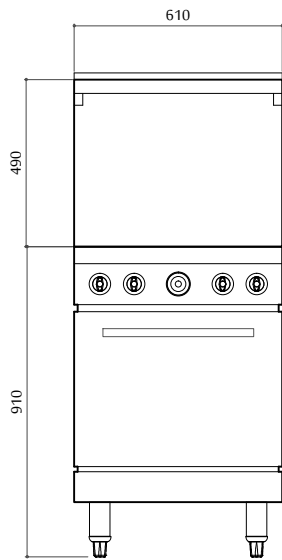

FRONT ELEVATION

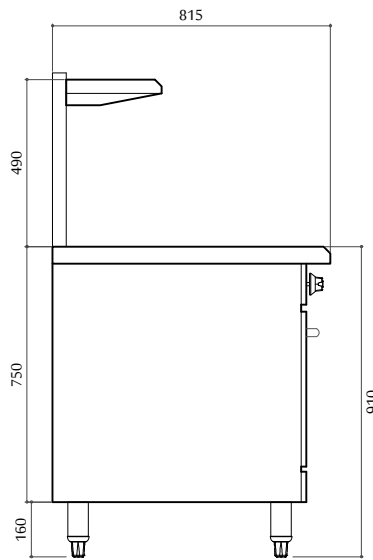

SIDE ELEVATION

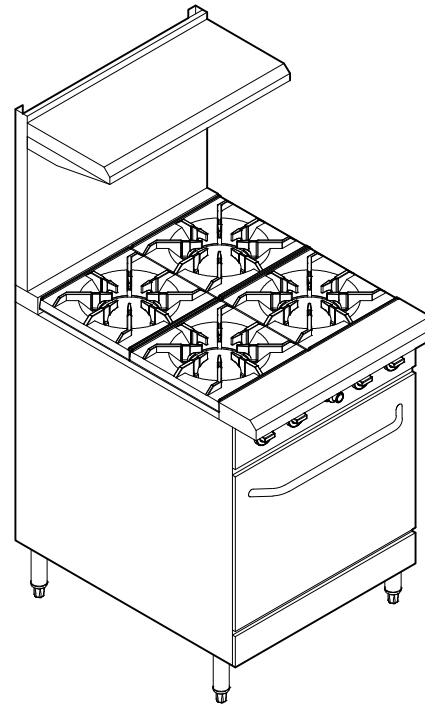

**UNI-FAB METAL INDUSTRIES**

Cavite Office:  
29 South Coast Industrial Estate Bancal, Carmona Cavite  
Tel. No.: 584-4820 to 21, 584-4884; (046) 413-0759  
Manila Office:  
950-956 Espeleta Street, Santa Cruz, Manila  
Tel. No.: 733-8241 to 52 Fax No.: 734-7216



Company: \_\_\_\_\_

Project Name: **SOUS-VIDE WOFEX 2014**

Item/Equipment Name:  
**4-BURNER RANGE W/ OVEN : ROYAL MODEL RR-4**

Item No./Model No.: **5** Qty.: **8 UNITS**

Dimensions: (Millimeter)			
Length	Width	Height	B.S. / O.S.
610	815	915	515

**Specifications:**

**OVEN:**

- » 20" WIDE TO FIT FULL SIZE SHEET PAN @ 18" x 26"
- » PORCELAIN FINISH ON CONTACT SURFACES
- » STANDING PILOT W/ 100% SHUT DOWN
- » U-BURNER RATED @ 27,000 BTU/Hr

**OPEN BURNER:**

- » STAINLESS STEEL FRONT, SIDES, LANDING LEDGE, BACKGUARD, SHELF, VALVE COVER & KICK PLATE
- » HEAVY GAUGE WELDED FRONT FRAME
- » 2-PIECE LIFT OFF CAST IRON BURNER RATED @ 30,000 BTU/Hr
- » 6" LEGS W/ ADJUSTABLE FEET
- » PROTECTED STANDING PILOT FOR EACH BURNER
- » 12" x 12" CAST IRON TOP GRATE W/ DOUBLE ANGLE SLOPE FOR EFFICIENT HEATING

DUE TO CONTINUOUS PRODUCT IMPROVEMENT, SPECIFICATIONS AND FEATURES CAN CHANGE WITHOUT PRIOR NOTICE:

**EQUIPMENT PERSPECTIVE**

Sheet Contents:	Revision #	Description of Change	Originator	Revision Date:
<input checked="" type="checkbox"/> Perspective	00	INITIAL RELEASE	DON	
<input type="checkbox"/> Specifications	01			
<input type="checkbox"/> Section Details	02			
<input type="checkbox"/> Elevation	03			
Pages: <u>1</u> / <u>1</u>	04			

Prepared & Checked By: \_\_\_\_\_  
Date: **DON 17JUN14**  
Customer's Approval: \_\_\_\_\_  
Date: \_\_\_\_\_

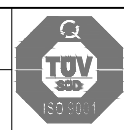



**UNI-FAB METAL INDUSTRIES**

Cavite Office:  
29 South Coast Industrial Estate Bancal, Carmona Cavite  
Tel. No.: 584-4820 to 21, 584-4884 ; (046) 413-0759  
Manila Office:  
950-956 Espeleta Street, Santa Cruz, Manila  
Tel. No.: 733-8241 to 52 Fax No.: 734-7216



Company: _____			
Project Name:		<b>SOUS-VIDE KITCHEN</b>	
Item/Equipment Name: <b>PREPARATION TABLE</b>			
Item No./Model No.:	<b>4</b>	Qty.:	<b>1 UNIT/S</b>
Dimensions: (Millimeter)			
Length	Width	Height	B.S. / O.S.
1500	700	865	150

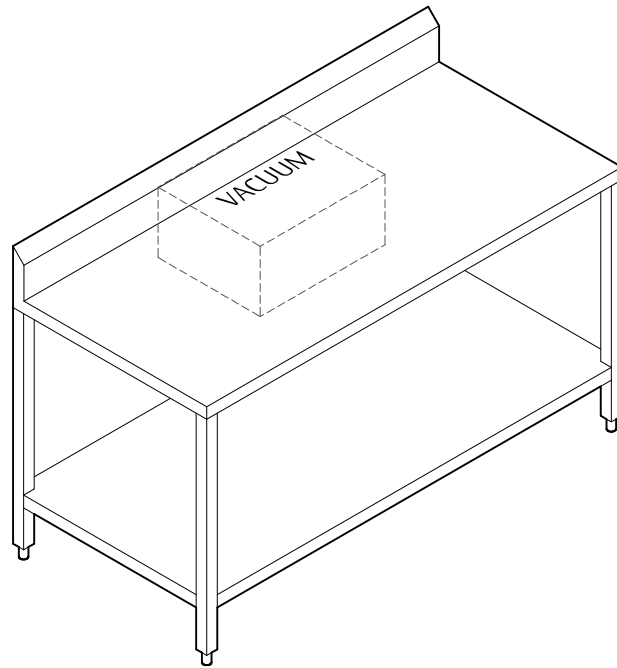

**Specifications:**

**MATERIALS:**

- » 16ga ss#4: top plate, back splash
- » 18ga ss: post frame, stiffener
- » 20ga ss#4: under shelf
- » 38square tube: upright
- » adjustable bullet type footing

DUE TO CONTINUOUS PRODUCT IMPROVEMENT, SPECIFICATIONS AND FEATURES ARE CHANGED WITHOUT PRIOR NOTICE.

**EQUIPMENT PERSPECTIVE**

Sheet Contents:	Revision #	Description of Change	Originator	Revision Date:
<input checked="" type="checkbox"/> Perspective	00	INITIAL RELEASE	DON	
<input type="checkbox"/> Specifications	01			
<input type="checkbox"/> Section Details	02			
<input type="checkbox"/> Elevation	03			
Pages: ___ OF ___	04			

Prepared & Checked By:   
Date: 22JUN12

Customer's Approval: \_\_\_\_\_  
Date: \_\_\_\_\_

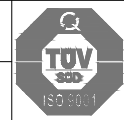

**UNI-FAB METAL INDUSTRIES**

Cavite Office:  
29 South Coast Industrial Estate Bancal, Carmona Cavite  
Tel. No.: 584-4820 to 21, 584-4884 ; (046) 413-0759  
Manila Office:  
950-956 Espeleta Street, Santa Cruz, Manila  
Tel. No.: 733-8241 to 52 Fax No.: 734-7216



Company: \_\_\_\_\_

Project Name: **SOUS-VIDE KITCHEN**

Item/Equipment Name: **EQUIPMENT STAND**

Item No./Model No.: **2** Qty.: **1 UNIT/S**

Dimensions: (Millimeter)			
Length	Width	Height	B.S. / O.S.
1500	700	865	150

- Specifications:**  
**MATERIALS:**
- » 16ga ss#4: top plate, back splash
  - » 18ga ss: post frame, stiffener
  - » 20ga ss#4: under shelf
  - » 38square tube: upright
  - » adjustable bullet type footing

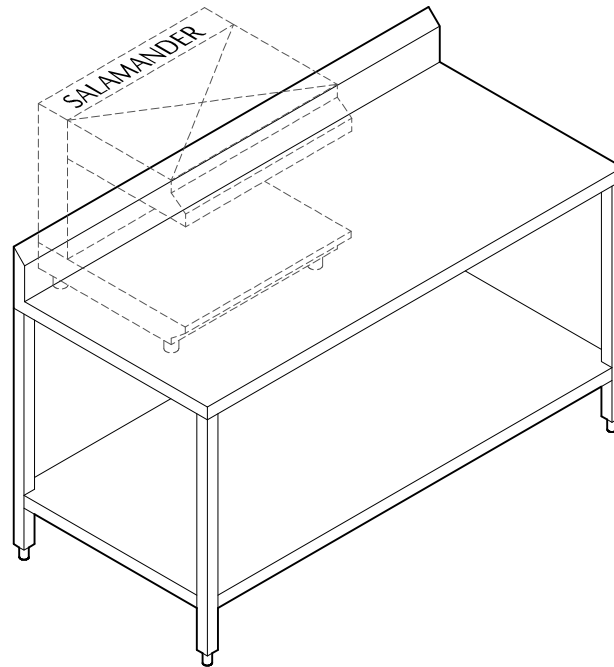

DUE TO CONTINUOUS PRODUCT IMPROVEMENT, SPECIFICATIONS AND FEATURES ARE CHANGED WITHOUT PRIOR NOTICE.

**EQUIPMENT PERSPECTIVE**

Sheet Contents:	Revision #	Description of Change	Originator	Revision Date:
<input checked="" type="checkbox"/> Perspective	00	INITIAL RELEASE	DON	
<input type="checkbox"/> Specifications	01			
<input type="checkbox"/> Section Details	02			
<input type="checkbox"/> Elevation	03			
Pages: ___ OF ___	04			

Prepared & Checked By:   
Date: **03MAR14**

Customer's Approval: \_\_\_\_\_  
Date: \_\_\_\_\_

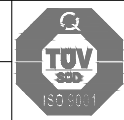

**UNI-FAB METAL INDUSTRIES**

Cavite Office:  
29 South Coast Industrial Estate BanCAL, Carmona Cavite  
Tel. No.: 584-4820 to 21, 584-4884 ; (046) 413-0759  
Manila Office:  
950-956 Espeleta Street, Santa Cruz, Manila  
Tel. No.: 733-8241 to 52 Fax No.: 734-7216

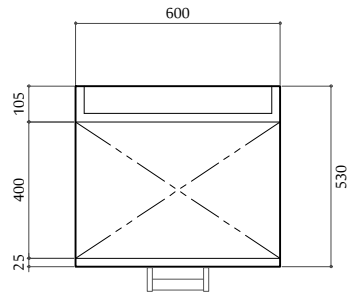

TOP VIEW

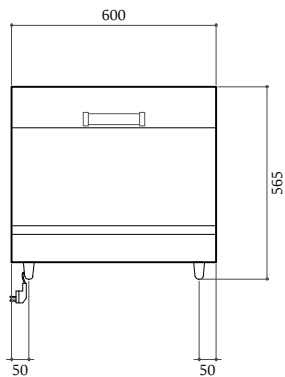
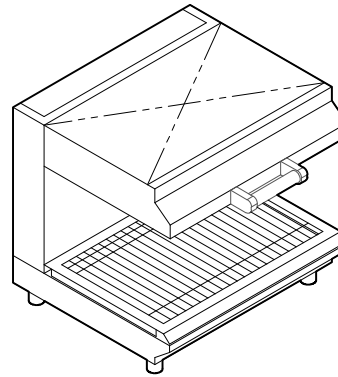

FRONT ELEVATION

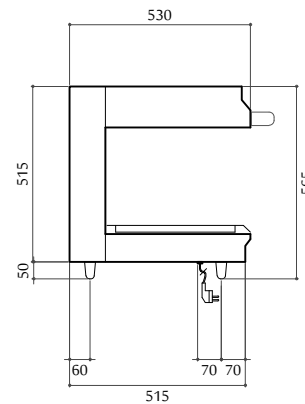

SIDE ELEVATION

Company: _____			
Project Name: <b>SOUS-VIDE WOFEX 2014</b>			
Item/Equipment Name: <b>SALAMANDER : OZTI MODEL OS 200</b>			
Item No./Model No.:	1	Qty.:	1 UNIT
Dimensions: (Millimeter)			
Length	Width	Height	B.S. / O.S.
600	530	565	_____

**Specifications:**

- » STAINLESS STEEL BODY
- » ERGONOMIC DESIGN
- » EASY TO CLEAN
- » LONG LIFE
- » 240V / 1NPE / 60Hz / 3.6kW

DUE TO CONTINUOUS PRODUCT IMPROVEMENT, SPECIFICATIONS AND FEATURES CAN CHANGE WITHOUT PRIOR NOTICE:

**EQUIPMENT PERSPECTIVE**

Sheet Contents:	Revision #	Description of Change	Originator	Revision Date:
<input checked="" type="checkbox"/> Perspective	00	INITIAL RELEASE	DON	
<input type="checkbox"/> Specifications	01			
<input type="checkbox"/> Section Details	02			
<input type="checkbox"/> Elevation	03			
Pages: 1/	04			

Prepared & Checked By:	DON	
Date:	17JUN14	
Customer's Approval:	_____	
Date:	_____	

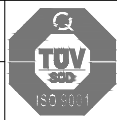

Note: This form and its contents are intellectual property of Uni-Fab Metal Industries, Inc. Any reproduction / usage without proper consent is prohibited.

PRODUCT:	QTY:	ITEM#
----------	------	-------



**Standard Features:**

- Drop-in countertop design with stainless steel edging, aluminum housing and control box, heavy duty electronic components, and high impact, thick, ceramic-glass top engineered for use in commercial kitchens
- Control knob for ease of use and automatic power or temperature control
- SmarTemp<sup>™</sup> Temperature control allows for specific temperature settings and 20 power cook settings
- Pan Maximizer feature achieves maximum heating rate of any induction compatible pan
- Drop-in cooktops and control boxes engineered and manufactured for easy installation
- Microprocessor monitors vital components 120 times per second to check for overheating, power supply problems, and more. Cooktop shuts off and displays error codes enabling user to diagnose and fix minor problems
- LED display for precise user feedback
- Automatic pan detection allows for instant energy transmission to pan, and no energy use when pan is not present
- Automatic shut-off feature prohibits overheating
- Easy-to-clean, smooth, ceramic-glass top surface
- Integral cooling fan keeps internal electronics cool
- Available in 1800 Watts (100-120V), 2500, 3000 and 3500 Watts (200-240V)
- One year limited warranty
- Made in the USA

**Specifications:**

Shall be a CookTek drop-in induction cooktop, Model \_\_\_\_\_ with a total kW rating of \_\_\_\_\_. Unit shall be manufactured in the United States and constructed with a stainless steel edging and aluminum control box. Unit shall be equipped with a built-in SmarTemp<sup>™</sup> microprocessor that performs precise temperature control, auto shut-off to prevent over-heating, self-diagnostics, and a pan maximizer feature that ensures maximum heating of induction compatible pan. Unit shall have an adjustable electronic control with 20 power cook settings and 27 precise temperature settings. Unit shall have a LED display located underneath the smooth top for precise user feedback. Unit shall operate on \_\_\_\_\_ volts \_\_\_\_\_ amps.

Note: Induction cooking requires the use of magnetic pots and pans.



**CookTek**  
MagnaWave™ Systems

**DROP-IN SINGLE HOB COOKTOP**  
MCD-1800, MCD-2500, MCD-3000, MCD-3500

DROP-IN SINGLE HOB COOKTOP MCD-1800, MCD-2500, MCD-3000, MCD-3500

DROP-IN SINGLE HOB COOKTOP MCD-1800, MCD-2500, MCD-3000, MCD-3500

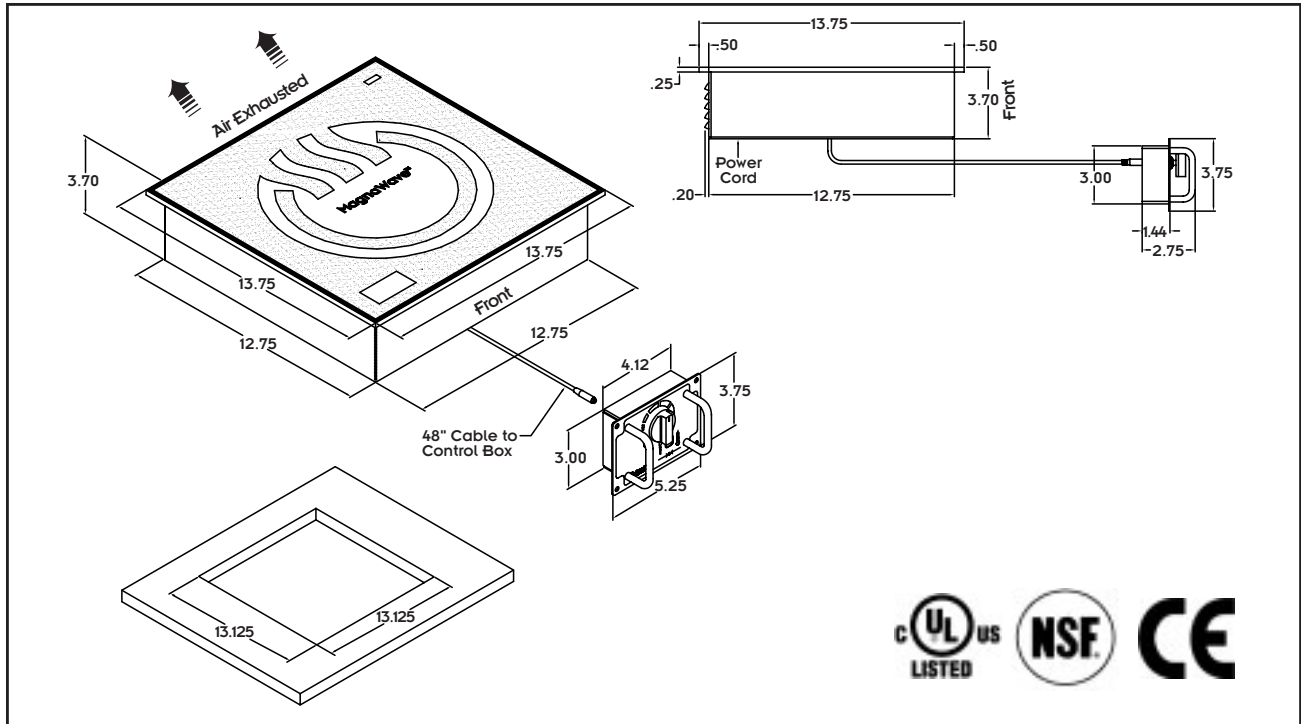

**SPECIFICATIONS:**

	<b>MCD-1800</b>	<b>MCD-2500</b>	<b>MCD-3000</b>	<b>MCD-3500</b>
Power requirements	100-120V, 1PH	200-240V, 1PH	200-240V, 1PH	200-240V, 1 PH
Power consumption	1800 Watts	2500 Watts	3000 Watts	3500 Watts
BTU comparison	16,000 BTU	22,000 BTU	26,000 BTU	31,000 BTU
Voltage	100-120V 50/60Hz	200-240V 50/60Hz	200-240V 50/60Hz	200-240V 50/60Hz
Amperage	15 amps (at max. setting)	11 amps (at max. setting)	13 amps (at max. setting)	15 amps (at max. setting)
Power range	100-1800W	100-2500W	100-3000W	100-3500W
Temperature range	85 - 500F 30 - 260C	85 - 500F 30 - 260C	85 - 500F 30 - 260C	85 - 500F 30 - 260C
Surface dimensions (inches) (cm)	13.75L x 13.75W x 3.7H 34.9L x 34.9W x 9.4H	13.75L x 13.75W x 3.7H 34.9L x 34.9W x 9.4H	13.75L x 13.75W x 3.7H 34.9L x 34.9W x 9.4H	13.75L x 13.75W x 3.7H 34.9L x 34.9W x 9.4H
Weight Packaged weight	15 lbs (6.8 kg) 18 lbs (8.2 kg)	15 lbs (6.8 kg) 18 lbs (8.2 kg)	15 lbs (6.8 kg) 18 lbs (8.2 kg)	15 lbs (6.8 kg) 18 lbs (8.2 kg)
Packaging (inches) dimensions (cm)	19.0L x 19.0W x 14.5H 48.3L x 48.3W x 36.8H	19.0L x 19.0W x 14.5H 48.3L x 48.3W x 36.8H	19.0L x 19.0W x 14.5H 48.3L x 48.3W x 36.8H	19.0L x 19.0W x 14.5H 48.3L x 48.3W x 36.8H
North American Cord length & plug*	6 Ft., NEMA 5-15P	6 Ft., NEMA 6-20P	6 Ft., NEMA 6-20P	6 Ft., NEMA 6-20P
Control box lead length	40 inches (101.6 cm)	40 inches (101.6 cm)	40 inches (101.6 cm)	40 inches (101.6 cm)
Warranty	One year limited warranty	One year limited warranty	One year limited warranty	One year limited warranty
Cooling clearance	2" (5.1 cm) at rear 6" (15.2 cm) from bottom	2" (5.1 cm) at rear 6" (15.2 cm) from bottom	2" (5.1 cm) at sides and rear 6" (15.2 cm) from bottom	2" (5.1 cm) at sides and rear 6" (15.2 cm) from bottom
Max. counter thickness	1" (2.5 cm)	1" (2.5 cm)	1" (2.5 cm)	1" (2.5 cm)

\*IEC Connector for 200V and higher units. International cord length = 2.5m (8.2ft).

Note: Many local codes exist, and it is the Owner and Installer's responsibility to comply with those codes. It's CookTek's policy to continually improve its products, and we reserve the right to change or improve our specifications without notification.



**CookTek**  
810 West Washington Blvd.  
Chicago, Illinois 60607 USA  
[www.cooktek.com](http://www.cooktek.com)

Tel: 1.312.563.9600 Fax: 1.312.432.6220  
Toll Free: 1.888.COOKTEK (266-5835)  
Toll Free Fax: 1.888.COOKFAX (266-5329)

